

Triple Air Bar Feeds

Triple Air pneumatic bar feeds are designed to work with nearly all 2 axis CNC machining centers with a spindle diameter up to 1 1/16". Triple Air bar feeds are a simple, flexible, safe and reliable alternative to expensive hydraulic bar feeds. Our bar feeds are available in 5/8" and 1 1/16" capacities, in 6' or 12' lengths. All barrels are interchangeable, so by ordering optional barrels, it is very easy to change material sizes as needed. Triple Air bar feeds come complete with all parts necessary for operation, including; pressure regulator, oiler, flow control material pusher with bearing, end-of-bar switch and installation kit. All bar feeds are assembled and tested prior to shipment. Ready to operate.



All Triple Air bar feeds feature:

1. Durable powder-coated finish.
2. American made components.
3. Cone roller nose pusher and piston are equipped with bearings.
4. Double safety lockout on pneumatics.
5. Quick barrel changes.
6. Pre-wired end-of-bar switch with PCL connection for Omniturn GT-75.
7. Complete with concrete anchors and concrete drill bit.
8. Affordable.

\$3,500.00

Complete bar feed systems

6' x 5/8"
12' x 5/8"
6' x 1-1/16"
12' x 1-1/16"

Bar feed tube and pusher only
- for change overs

6' x 5/8" \$600
12' x 5/8" \$670
6' x 1-1/16" \$640
12' x 1-1/16" \$730



4 3 2 1

D

D

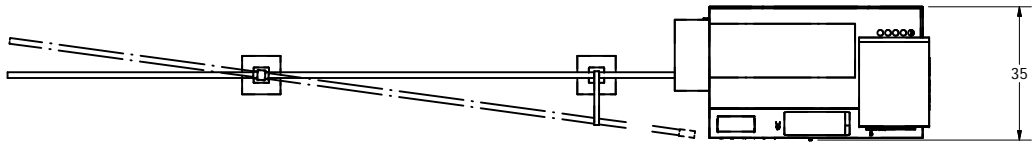

35

C

C

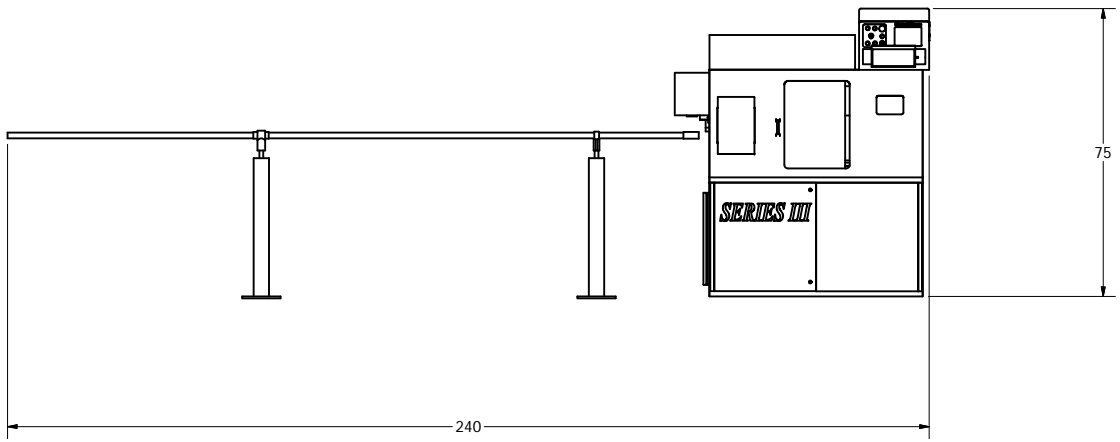

240

75

B

B

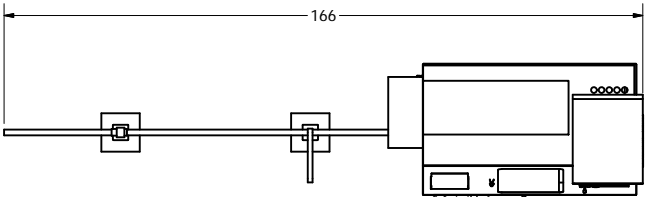

166

B

B

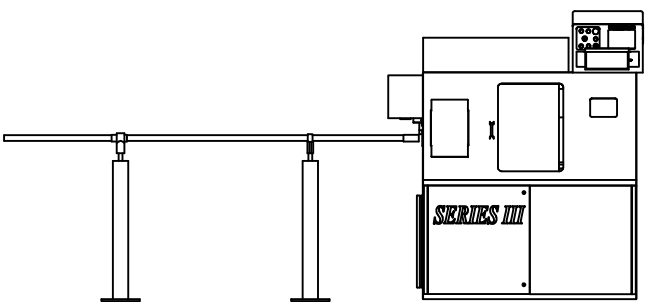

A

A

4 3 2 1

| | | | | | |
|----------|----------|-----------|--------------------------------|------------------------------|-----|
| DRAWN | JRichlin | 7/28/2006 | TripleAir 12' and 6' Barfeeder | | |
| CHECKED | | | | | |
| QA | | | TITLE | | |
| MFG | | | | | |
| APPROVED | | | | | |
| | | | SIZE | DWG NO | REV |
| | | | C | Gt with 12' and 6' Tripleair | |
| | | | SCALE | SHEET 2 OF 2 | |