

NPT 1/8 pipe thread - OD

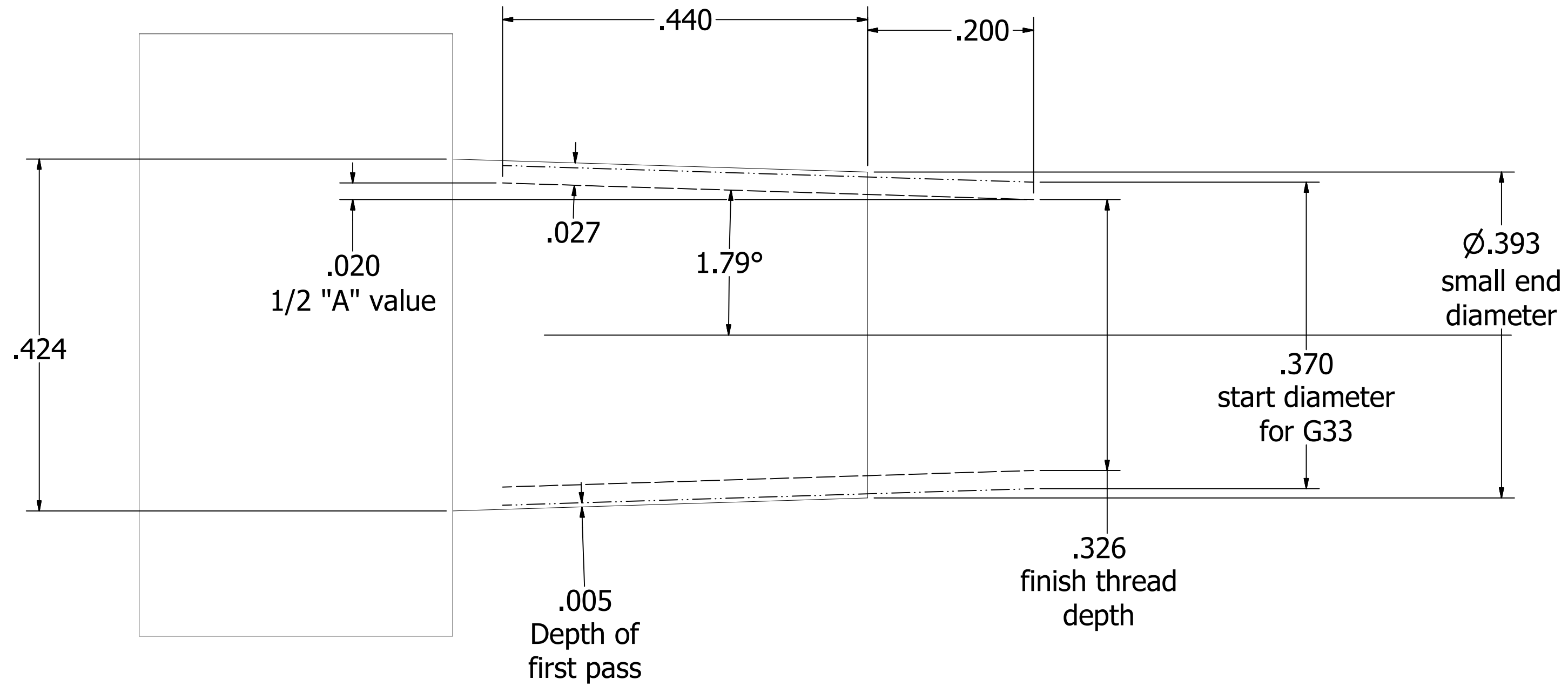

T1 (thread tool)
 x.370 z1
 z.2
 G33 x.326 z-.4 i.025 k.037 c a.04
 g00z1

DRAWN JRichlin	6/13/2014	Richlin Machinery Inc Engineered - To - Order (631) 694-9400		
		TITLE 1-8 pipe thread		
Rev 0		SIZE C	DWG NO 1-8 pipe thread	REV 0
Material Generic		SCALE		SHEET 1 OF 1